

Interface

Accessories

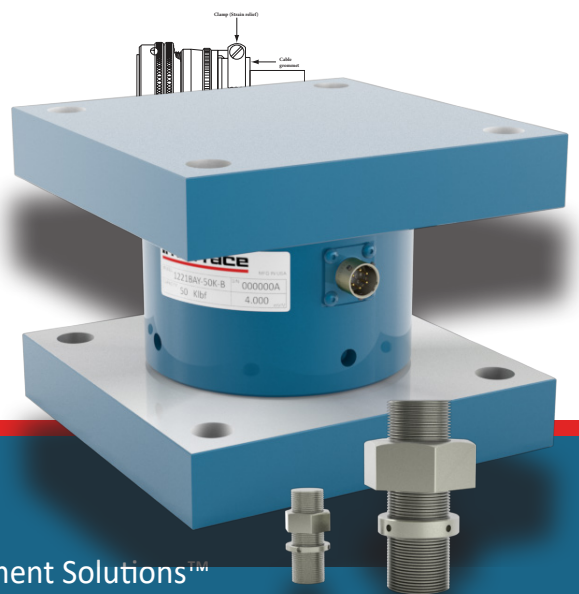
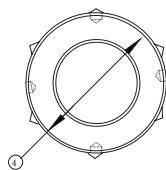
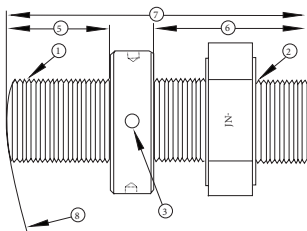
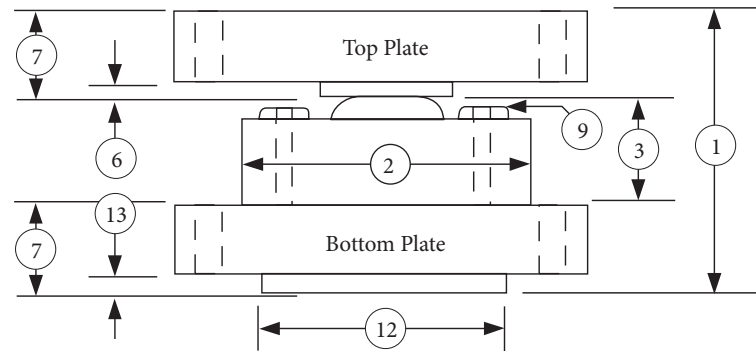
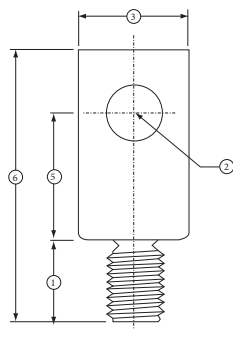
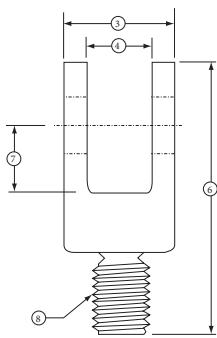
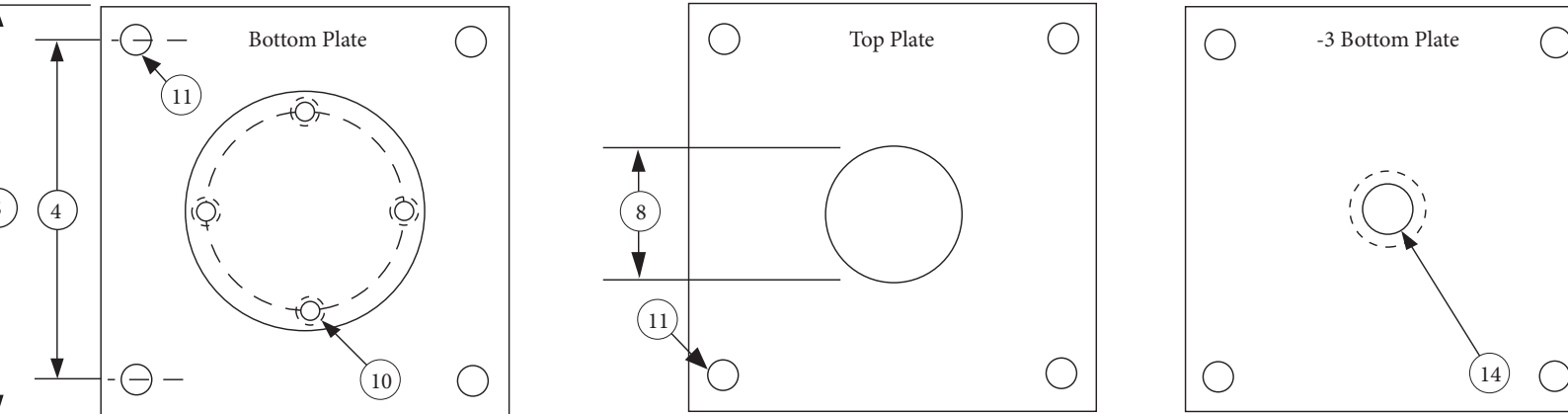

Interface Accessories v1.0 01-13-2020

Interface
FORCE MEASUREMENT SOLUTIONS

The World Leader in Force Measurement Solutions™

nbn Austria GmbH

nbn

Interface accessories are made from the highest components and processes to ensure your Interface products perform to meet their published specifications.

Interface provides everything from shielded cable and mating connectors to calibration adapters and resistors. Our top and bottom plates distribute a load over the support structure foundation and provides a prepared surface for the load cell. Precisely machined clevises, jam nuts, thread adapters, and rod end bearings provide rigid connections and reduce alignment error. Load cell and torque transducer accessories are available in many design configurations and will help you complete your project design with the highest performance and the least amount of trouble possible.

Cable Assemblies

- Interface uses the highest grade cables and connectors to ensure the performance of your force and torque systems are at the highest level.
 - For connecting transducers to instrumentation
 - Standard and custom lengths
 - Shielded cable

Calibration Adapters

- Interface Calibration Adapters use high-grade alloy steel and stainless steel, heat treatment, and machining practices to ensure that the performance of your transducer is maintained to factory standards.
 - Improves accuracy
 - Spherical end for compression loading
 - Metric sizes available

Clevises

- Interface provides high-grade clevises that will perform in your application as needed while maintaining the level of performance you expect from Interface products.
 - Precision machined
 - Commonly used with REBs
 - Male threads

Jam Nuts

- Interface Jam Nuts are manufactured to ensure the strength and performance is maintained for your solution.
 - Used with REBs, clevises and calibration adapters
 - Flat, parallel surfaces
 - Standard thread sizes

Load Buttons

- Interface Load Buttons (LBS) and ConvexBT are made from high-grade alloy and stainless steel, heat treated, and precision-machined to ensure that the performance of your transducer matches the calibrated at the factory.
 - Converts universal cell to compression only
 - Spherical loading surface
 - For LowProfile, “S” type and Mini load beam

Mating Connectors

- Interface Mating Connectors are the highest grade ensure that the performance of your force and torque solutions are not compromised.
 - Mating connector and cable
 - Dressed pigtails
 - Interconnects between load cell and instruments

Mounting Plates

- Interface Mounting Plates, made from the best grade alloy and stainless steel, are machined to the tightest specifications and are designed specifically to maintain the performance of the load cell in your application.
 - Distributes the load over the foundation of the supporting structure
 - Provides a prepared surface for the load cell
 - Eliminates the requirement for expansion assemblies in most installations

RCAL Resistors

- Interface RCAL Resistors are high-precision components and provide an effective, method for checking the calibration of a load cell system in the field or when a means of applying actual forces is unavailable.
 - Precision wire-wound
 - 5 ppm/°C, 0.01%
 - Used for shunt calibration

Rod End Bearings

- Interface Rod End Bearings help to couple your load cell to your application solution while maintaining the performance of your load cell.
 - For tension applications
 - Reduces alignment error
 - Metric sizes available

Thread Adapters

- Interface Thread Adapters are manufactured with the best practices to ensure that the performance of your transducer is maintained when attached to your force transducer application.
 - Adapts male to female
 - Common Interface thread sizes
 - Adapts one thread size to another

Transducer Electronic Data Sheet (TEDS)

- Interface TEDS provides a force or torque transducer with electronic identification, allows sensors and instruments to be “plug and play ready.” It meets IEEE 1451.4 Standard for Smart Transducer interfacing and is available on new or existing sensors.
 - Provides sensor with electronic identification
 - Plug and Play Ready
 - Meets IEEE 1451.4 standard for smart transducer interface
 - Contains sensor information and calibration data
 - Available on new or existing sensors



Cable Assemblies Interconnectors
Standard and custom lengths



CA Calibration Adapters
Metric sizes available



CLV Clevises
Male threads



JN Jam Nuts
Standard thread sizes



LB Load Buttons
Converts universal cell to compression only



MC/CN Mating Connectors
Interconnects between load cell and instruments

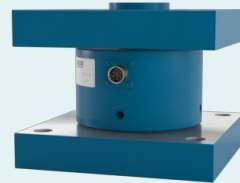

TP/BP Mounting Plates
Bottom Plates
Top Plates



RS RCAL Resistors
Used for shunt calibration



REB Rod End Bearings
Metric sizes available



TA/THD Thread Adapters
Common Interface thread sizes



TEDS Transducer Electronic Data Sheet
Contains Sensor Information and Calibration Data



JB104SS 4-Channel Stainless Steel Junction Box
4-Channel Summing

ACCESSORY TIPS

Cable Length and Temperature Effects

For high accuracy force measurement the effects of the cable on the measurement must be considered. For constant voltage excitation there are two effects of significance.

- An effect on the sensitivity due to voltage drops over the cable length.
- An effect on the thermal span characteristics of the load cell due to the change of cable resistance with temperature.

Cable Length Effects - If the load cell is purchased with a cable of any length, the sensitivity is determined with the installed cable in calibration and this is not a problem. For load cells with connectors, or if a cable is added that is not designed for the exact use, there will be a loss of sensitivity of approximately 0.37% per 10 feet of 28 gage cable and 0.09% per 10 feet of 22 gage cable. This error can be eliminated if a six wire cable is run to the end of the load cell cable or connector and used in conjunction with an indicator that has sense lead capability.

Temperature Effects - Since cable resistance is a function of temperature, the cable response to temperature change affects the thermal span characteristics of the load cell cable system. For 6-wire systems this effect is eliminated. For 4-wire cables the effect is compensated for in the standard cable lengths offered with the load cells if the load cell and cable are at the same temperature at the same time. For non-standard cable lengths, there will be an effect on thermal span performance. The effect of adding 10 feet of 28 gage cable is to cause a decrease in sensitivity with temperature equal to 0.0008%/°F. For an added 10 feet of 22 gage cable the effect is to decrease sensitivity by 0.0002%/°F. In some cases, it is tolerable to degrade performance since Interface standard specification is extremely tight. However, for long cable runs or high accuracy applications, this can be a significant factor. The best approach to eliminate the problem is to run six wires to the end of the standard cable length and sense the excitation voltage at that point.

ACCESSORY TIPS

TEDS IEEE 1451.4

Interface has offered load cells with various types of SELF-ID for many years. The SELF-ID feature eliminates the need to enter data via a keyboard or key panel from a paper calibration sheet into the instrument used with the load cell. TEDS offers the following benefits:

- Eliminates potential for data entry error
- Cuts time in half to set up instrument
- Makes swapping of load cells easy
- Increases safety by making certain that system has the correct capacity of the load cell
- Can be used to identify location of load cell
- No need to store calibration sheets, no more paper, no more concern about lost sheets
- Makes inventory control of your load cells easy
- Load cells can be changed out without jeopardizing integrity of system

Now TEDS (Transducer Electronic Data Sheet) provides additional advantages over proprietary SELF-ID because it is an industry standard (IEEE 1451.4) which has the potential to permit mix and matching of load cells and instruments from different manufacturers. IEEE1451.4 specifies a table of identifying parameters that are stored in the load cell in the form of a TEDS. TEDS is a table of parameters that identify the transducer and is held in the transducer on a EEprom for interrogation by external electronics.

- Transducer Electronic Data Sheet (TEDS) SELF-ID Load Cell
- Load cell with electronic identification inside
- Meets IEEE 1451.4 standard for smart transducer interface
- Available on new or existing load cells
- Plug & Play Ready
- Cuts instrument setup time
- Eliminates data entry error
- Sensor information and calibration data

Mounting Plates for Low Profile™ Load Cells

The installation of a compression load cell under a weigh bridge, tank, or other structure normally requires that mounting plates be used. The bottom plate, ground flat to 0.0002 T.I.R. to mate with the load cell and fabricated of mild steel, distributes the load over the foundation or supporting structure and provides a prepared surface for the load cell.

The top plate distributes the load to the weighing structure and provides a hard (Rc 45) surface for the load button. The top plate will move on the button due to thermal expansion, load shifting, wind loading, and other side loads. The high side load capacity of the Interface load cell eliminates the requirement for expansion assemblies in most installations. Mounting plates are suitable for compression loads only; they will not properly support a universal load cell used in tension.

Using a Shunt Calibration Resistor

Since a strain gage load cell is a passive electrical device, there exists a simple, yet effective, method for checking the calibration of a load cell system in the field or when a means of applying actual forces is unavailable. Inducing an electrical imbalance in the cells bridge circuit will simulate the bridge imbalance caused by the application of actual forces to the load cell. Then the system gain may be adjusted so that the system output signal or display indicates a known force on the load cell.

Important Note:

Be careful not to use shunt calibration as a substitute for actual force calibration of a system. Shunt calibration merely supplies a known signal to the signal conditioning unit, in order to check its gain or span adjustment.

Interface Accessories

- Cable Assemblies
- Calibration Adapters
- Clevises
- Jam Nuts
- Load Buttons
- Mating Connectors
- Mounting Plates
- RCAL Resistors
- Rod End Bearings
- Thread Adapters
- TEDS

Interface force measurement accessories are available in many design configurations for project designs requiring the highest performance.

To learn more about the Interface products or force measurement solutions call 480-948-5555.

Interface is the world's trusted leader in technology, design and manufacturing of force measurement solutions. Our clients include a "who's who" of the aerospace, automotive and vehicle, medical device, energy, industrial manufacturing, test and measurement industries.

Interface engineers around the world are empowered to create high-level tools and solutions that deliver consistent, high quality performance. These products include load cells, torque transducers, multi-axis sensors, wireless telemetry, instrumentation and calibration equipment.

Interface, Inc., was founded in 1968 and is a US-based, woman-owned technology manufacturing company headquartered in Scottsdale, Arizona.



7418 East Helm Drive, Scottsdale, AZ 85260 ▪ 480.948.5555 ▪ interfaceforce.com

Aufgrund laufender Weiterentwicklungen sind Änderungen der Spezifikationen vorbehalten. Alle Angaben vorbehaltlich Satz- und Druckfehler.

nbn Austria GmbH
Riesstraße 146, 8010 Graz

Tel. +43 316 40 28 05 | Fax +43 316 40 25 06

nbn
nbn@nbn.at | www.nbn.at